



STOP SUPER SPEEDERS COALITION CALL UPDATE

April 17, 2026

Tom@FamiliesForSafeStreets.org
FSS National Director

corey.hannigan@transalt.org
Government Relations Director for
Safe Streets

Kelly McConney Moore
NYU Policing Project
Kelly.Moore@nyu.edu





FAMILIES FOR SAFE STREETS

OUR MISSION

Families for Safe Streets confronts the preventable epidemic of traffic injuries and deaths through advocacy and support.

WHO WE ARE

FSS is comprised of 1200+ individuals who have lost loved ones, been injured, or care for someone who was, in traffic violence.

SUPPORT SERVICES

Providing peer support and logistical assistance.

ROAD SAFETY FOR ALL

Pedestrians, cyclists, drivers & passengers.

Learn more at familiesforsafestreets.org

SAFE SPEEDS

SAFE STREETS

SAFE VEHICLES

SUPPORT VICTIMS

PRIORITIZE MOST VULNERABLE



Crash Death Rates In High-Income Countries

The United States had the **highest motor vehicle crash death rate** compared with 28 other high-income countries

United States	11.1
Chile	10.5
Poland	7.7
Austria	4.7
Canada	4.7
Australia	4.7
Switzerland	2.2
Sweden	2.2
Norway	2.2
Avg (excluding US):	4.8

New York City	229 fatalities per year	51,756 injuries per year
	<i>A fatality every 38 hours</i>	<i>An injury every 10 minutes</i>
New York State	1,057 fatalities per year	155,048 injuries per year
	<i>A fatality every 8 hours</i>	<i>An injury every 4 minutes (17 injuries an hour)</i>

NYC: Traffic crashes [kill more New Yorkers](#) than gun violence.

- [30% of New Yorkers](#) have been injured in traffic violence, and 70% know someone who was injured or killed.
- For every person who dies on NYC streets, 11 are severely injured.

SPEEDING IS DEADLY



THE LIKELIHOOD OF FATALITY INCREASES EXPONENTIALLY WITH VEHICLE SPEED³²

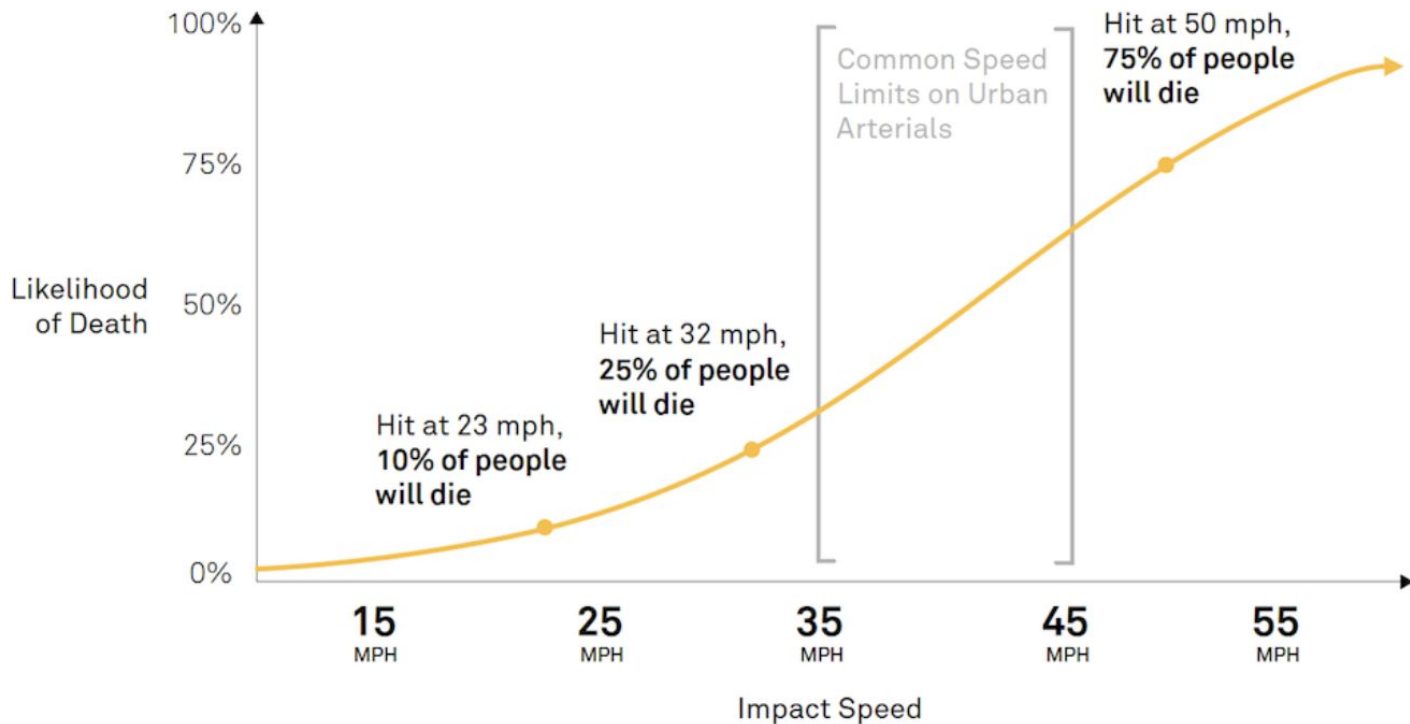



WHAT IS INTELLIGENT SPEED ASSISTANCE (ISA)

- Intelligent Speed Assistance technology, sometimes referred to as “speed limiters”, are devices that limit the speed of the vehicle.
- ISA is dynamically connected to the speed limit of the road using vehicle cameras and road signs, GPS and virtual maps, or both.
- When a vehicle attempts to exceed the speed limit, the ISA interfaces with the throttle to prevent acceleration beyond the posted speed limit, but does not interact with the brakes.
- ISA technology has been added to the NYC Fleet to much success, including a nearly 40% reduction in “hard braking events”.



TYPES OF ISA

FIXED

These devices prevent the vehicle from exceeding a single, programmed top speed (e.g., 80 mph). Trucks have had these for decades.

PASSIVE

Typically integrated into a car by the manufacturer, passive ISA systems warn the driver about the speed limit, but do not prevent speeding. (Required by EU and was proposed in CA but did not pass.)

ACTIVE

Can be installed in any vehicle and prevents drivers from exceeding the speed limit (or a set amount above it).

Used for Stop Super Speeders as an aftermarket device.

INSTALLATION

2-3 simple connections

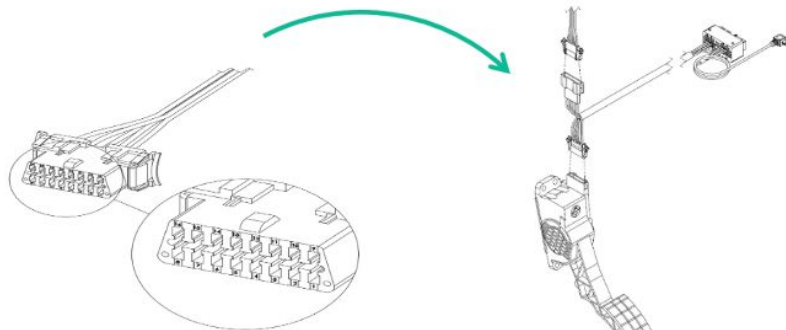

OBD Harness

Pedal harness
interceptor

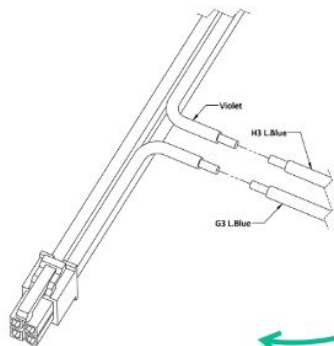

Brake Pedal connection

ISA Devices are Easy to Install



30-45 minutes to install

STOP SUPER SPEEDERS: Policy Approach

- Common sense effort – only addresses the most egregious offenders:
 - Less than one percent of NYC drivers
- Modeled after ignition interlock devices (“breathalyzers”) for drunk driving
- Mandates “active” ISA as an aftermarket device
- Studies show super speeders disproportionately cause harm

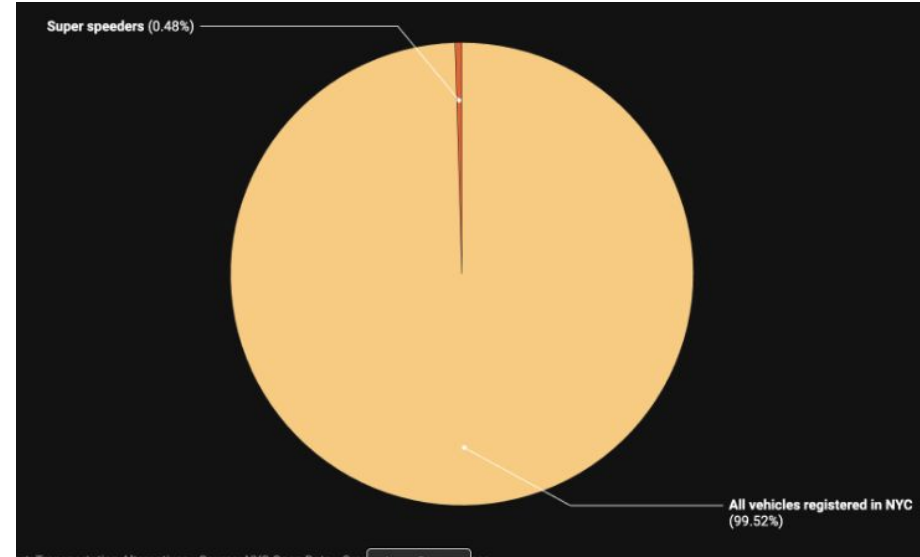

Source: [Lifestyle of the Rich and Reckless](#)



STOP SUPER SPEEDERS: A Small Number of Super Speeders Are Disproportionately Dangerous

Relative Risk of Being Involved in a Fatal or Severe Injury Crash

Number of Violations	Relative Risk	Number of Vehicles in 2023
16	Twice as likely	3,147
19	3 times as likely	1,796
20	4 times as likely	1,543
21	5 times as likely	1,347
23	10 times as likely	1,014
25	15 times as likely	746
30	50+	374

Source: [NYCDOT](#)

STOP SUPER SPEEDERS: They Put Everyone At Risk

- In 2025, the top 10 super speeders in New York State each received an **average of 179 school zone speed safety camera tickets, with the most reckless driver receiving 259** and the tenth most reckless driver receiving 132.
- More than 2.5 million New Yorkers — including over 500,000 children — live within a five-minute walk of an intersection where one of just these 10 drivers was caught speeding in 2025. That footprint also encompasses 2,376 schools or childcare facilities, 30 hospitals or urgent care centers, and 88 nursing homes.

New York's Top 10 Super Speeders & the Locations Where They Most Frequently Terrorize New Yorkers

New York's ten biggest speeders in 2025

- #1: Black 2023 Audi A6
- #2: Black 2017 Lexus IS
- #3: White 2023 RAM 1500
- #4 (tie): White 2022 Mercedes-Benz GLE-Class
- #4 (tie): Grey 2022 Chevrolet Malibu
- #6: White 2022 Ram 1500
- #7: Blue 2023 Chevrolet Silverado
- #8: Blue 2022 Mercedes-Benz A-Class
- #9: Grey 2024 BMW 760i
- #10: Grey 2024 Honda Passport

Violations at a single location in 2025

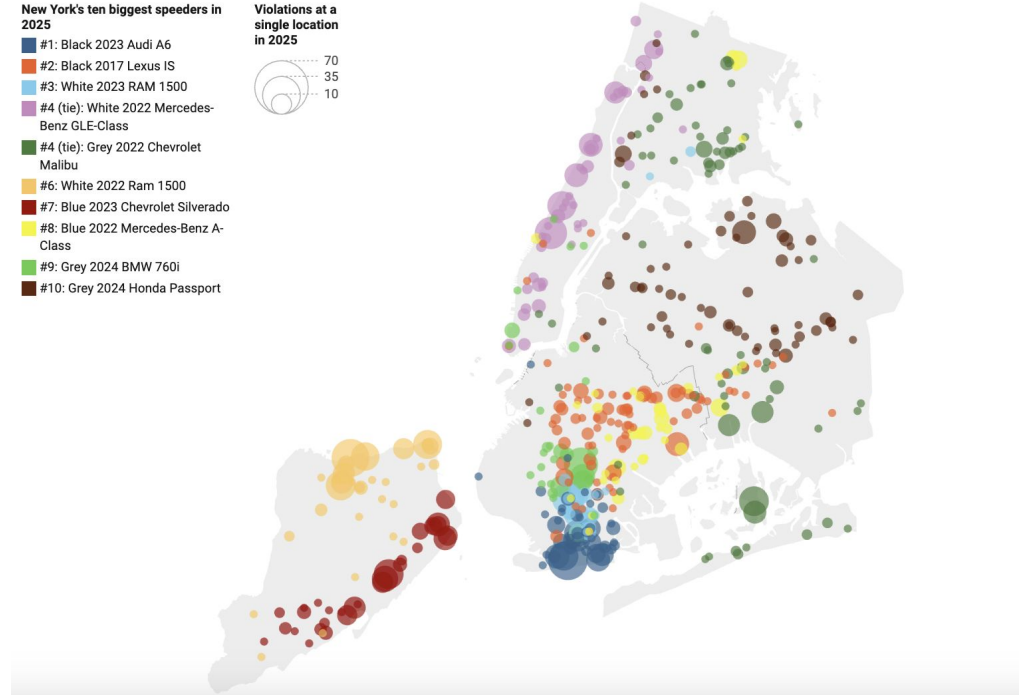



STOP SUPER SPEEDERS: They Put Everyone At Risk

4  **NEW YORK**

BROOKLYN

Chronic speeder gets up to 9 years for killing mom, 2 kids in Brooklyn crosswalk

Natasha Saada and her two daughters, Diana and Deborah, were killed in the March crash on Ocean Parkway.

STREETSBLOG NYC

Tyrik Mott, who cops said killed Apolline Mong-Guillemain in a crash in Clinton Hill on Sept. 11 after racking up close to 100 red-light and speed-camera tickets since 2017, had completed the so-called Driver Accountability Program — a 90-



STOP SUPER SPEEDERS: Benefits

- Effective behavior change to address the root cause: excessive speeding
- Does not deny anyone mobility – those with an ISA can continue to go to work, take care of kids, attend medical appointments
- Current approach of fines & license suspension is not working; 75% of drivers with suspended license drive anyway
- It is fair and non-carceral

STOP SUPER SPEEDERS: An Integral Component of Roadway Safety

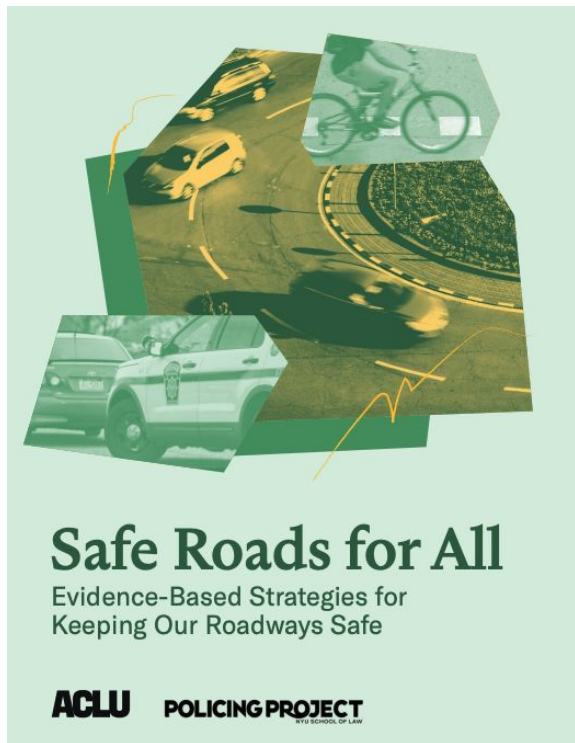

How We Move Forward: Evidence-Based Strategies for Keeping Roadways Safe	13
Strategy #1: Prioritizing Safety in Public Spaces.....	13
Strategy #2: Reforming Municipal Finance.....	16
Strategy #3: Addressing Enforcement Discretion.....	18
Strategy #4: Piloting Models of Civilian Enforcement.....	20
Strategy #5: Incentivizing Vehicular Safety & Safe Driving.....	23
Strategy #6: Leveraging Technology.....	24

Source:

<https://assets.aclu.org/live/uploads/2026/04/2026.04.13-SafeRoadsReport.pdf>



STOP SUPER SPEEDERS: Fair and Non-Carceral

February 3, 2026



TESTIMONY OF THE POLICING PROJECT AT NYU SCHOOL OF LAW TO THE JOINT LEGISLATIVE BUDGET COMMITTEE - TRANSPORTATION IN SUPPORT OF S.4045

We have done significant work to advance traffic safety, including collaborating with policymakers on legislation to more effectively use law enforcement resources when enforcing traffic violations. One approach we endorse are bill that reprioritize what offenses law enforcement focuses on, emphasizing those offenses most closely associated with crashes—such as speeding—rather than minor equipment issues with little connection to roadway safety. Another facet of improving traffic safety enforcement is smart utilization of innovative technologies that prevent of dangerous driving behaviors, reducing the need for enforcement and the accompanying harms.



STOP SUPER SPEEDERS: An Integral Component of Roadway Safety

<https://bit.ly/SafeRoadsforAll>

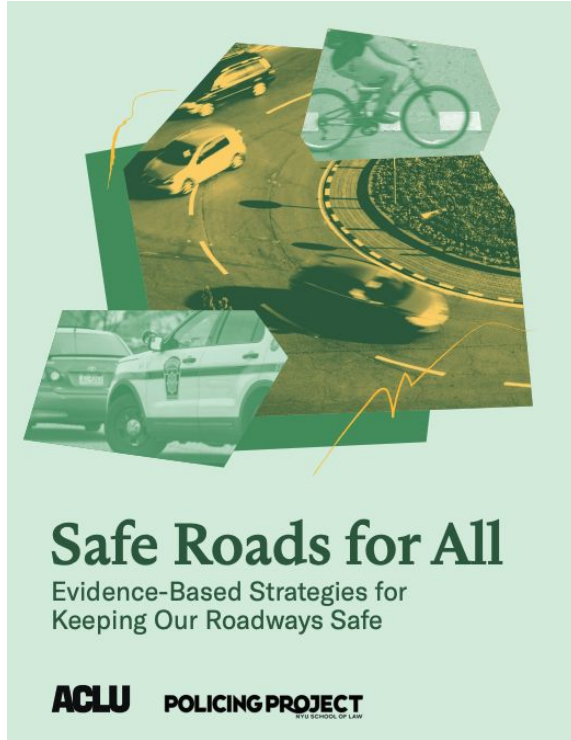

bitly



STOP SUPER SPEEDERS: Administrative Technology Is There

STREETSBLOG NYC

[Streetsblog NYC](#)

AUTOMATED ENFORCEMENT

How to Use Data to Fight For Safe Streets and Stop Super Speeders

College coders built a simple tool for DMV staff and administrators to identify repeat dangerous speeding behavior.



By Akash Lal

12:01 AM EST on January 29, 2026



In partnership with Data Science for Social Good and BetaNYC we hosted a Stop Super Speeders hack-a-thon in December 2025

See the Winning Team's Tutorial





STOP SUPER SPEEDERS: Supporters

- Over [170 local](#), state and national organizations in support
- Recognized by **National Highway Traffic Safety Administration** as a “Countermeasure that Works”
- The **National Transportation Safety Board** recommends its use
- The **National Road to Zero Coalition**’s Accelerating Technology Working Group issued recommendations to prevent speeding including ISA technology
- The **Association of American Motor Vehicle Administrators (AAMVA)** is supporting the approach and has created a task force that issued model legislation and will be issuing rule-making guidance





STOP SUPER SPEEDERS: Supporters



The New York Board of Rabbis
Where diversity and unity meet



STOP SUPER SPEEDERS: Public Support

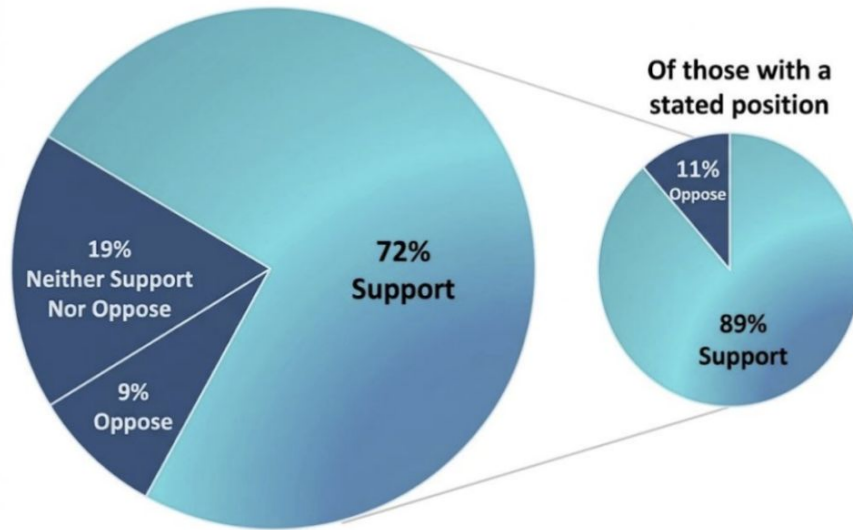

- 72% of Americans support the use of Intelligent Speed Assistance to slow the worst speeders.
- 89% with a stated position support it.



STOP SUPER SPEEDERS: Editorial Board Support

DAILY NEWS

By **NEW YORK DAILY NEWS EDITORIAL BOARD**

PUBLISHED: April 5, 2025 at 4:05 AM EDT

OPINION

Making the streets safer: Cap the speeds of dangerous drivers

Newsday

OPINION / EDITORIALS

'Super speeders' must be stopped from terrorizing us all

NEW YORK POST

OPINION EDITORIAL

Get real about consequences for New York's worst drivers

By Post Editorial Board

Published March 31, 2025 | Updated March 31, 2025, 7:47 p.m. ET

24 Comments



MOST COMMON QUESTION: How much will it cost?

- **Device Costs**

- Similar to the ignition interlock program.
- All costs are incurred by the offender, as outlined in model legislation:
 - Installation: Approximately \$150
 - Monthly Lease: Approximately \$4 per day
 - Removal: Approximately \$100
- Some states have additional one-time fees to pay for administration of the program.

- **Implementation**

- Most states find that 1 or fewer FTEs are needed to administer the program
- Startup costs can be between \$500K-\$1M, depending on the department, and ongoing costs are approximately \$100K each year.
- Administration of the program is similar to that of the ignition interlock device program.

STOP SUPER SPEEDERS: Mostly Luxury Vehicles, Paying Thousands in Fines

- Super speeders are 72% more likely to drive a new vehicle, and 57% more likely to drive a luxury vehicle than the average driver.
- The more speeding tickets a super speeder gets, the *more likely* they were driving a luxury vehicle:
- The average super speeder is spending \$4,890 in tickets.
 - **The average super speeder would save thousands of dollars under this program.**

Super speeders drive luxury vehicles.

While only a quarter of drivers on the road are operating luxury vehicles, they account for 40% of super speeders. Among the top 1,000 worst super speeders, the most common car brands are BMW and Mercedes Benz.

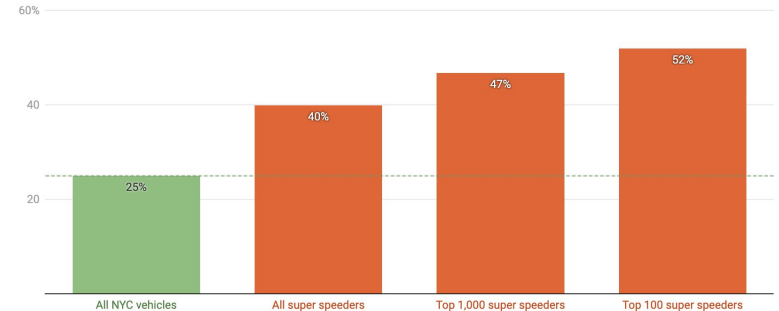

Source: [Lifestyle of the Rich and Reckless](#)

STOP SUPER SPEEDERS: National Context

- NYS was the first state to introduce a bill in August 2023
- Bi-partisan
- Bills have been enacted in a single session in District of Columbia, Virginia and Washington
- Maryland and Georgia legislatures passed bills in April 2026
- Arizona and Illinois have passed in one house (so far) in 2026
- 12 other bills this legislative session & many are progressing rapidly

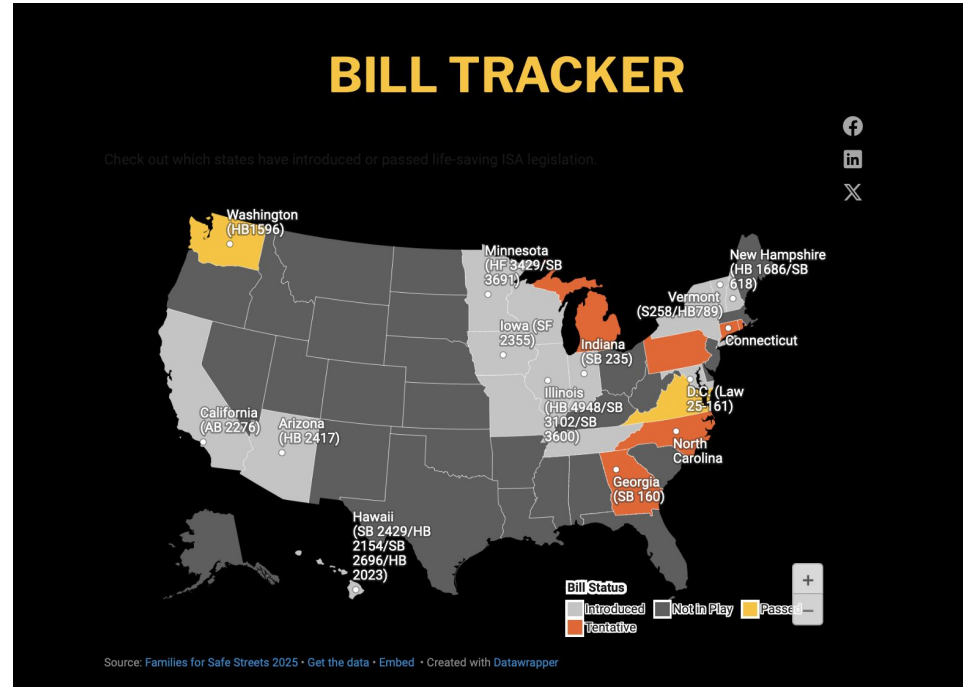

STOP SUPER SPEEDERS: New York State

- Included in the Governor's SoS and Executive Budget
 - FY 2027 Executive Budget Part D
- Establishes a NYC pilot program requiring ISA for repeated violations
- Authorizes the NYC to set parameters for the pilot.
- Pilot would take effect one year after enactment and expire on April 1, 2031.

- New York State Senate has included Stop Super Speeders in their budget proposal, as well.
- Being deliberated “at the table” right now





STOP SUPER SPEEDERS: State-of-Play

- Budget was due on April 1, running late
- Session resumes on Monday, April 20
- Some big items remain to be figured out, there may be one or two weeks left on the clock
- We need leadership to know this is a priority, particularly in the Assembly



STOP SUPER SPEEDERS: What You Can Do:

- Phone calls, emails, text messages directly to leadership/staff encouraging them to include SSS in the budget
- Outreach to your local senator or assemblymember encouraging them to reach out to leadership to emphasize this as a priority
- Calls to action to your members, drive emails and phone calls
- Join us in Albany on April 21 for a mini advocacy day!
- Social media validation

STOP SUPER SPEEDERS: White Paper

Provides information on:

- Super speeders & data showing they disproportionately cause harm
- What is intelligent speed assistance and how does it work
- What is best practice for legislation & rulemaking
 - Who specifically should get the device
 - Penalties for non-compliance
 - Low-income provisions
 - Privacy
 - Reporting & evaluation
 - Implementation timeline
 - And much more!

Details at familiesforsafestreeets.org/stop-super-speeders



Stop Super Speeders

A Policy White Paper on Requiring Intelligent Speed Assistance for High-Risk Drivers



FSS SUPPORT SERVICES



SUPPORT COMMUNITY CALENDAR

Families for Safe Streets offers monthly support community virtual meetings available to anyone who is experiencing the loss or trauma from a traffic crash. In addition to the calendar of events listed here, we hold a special monthly Spanish-speaking group and a quarterly peer mentor training.

Reunión con Miembros de FSS en Español: FSS convoca a nuestros miembros de habla hispana mensualmente para que se reúnan, compartan experiencias, conecten entre sí y construyan una sólida comunidad de apoyo de FSS en español.

Please visit: familiesforsafestreeets.org/calendar for details and to register.

Please contact us if you need a peer mentor to be matched at any time.

July 19, 2023 Post-Crash Body Perceptions

This is a special workshop for crash survivors. Traumatic injury can alter the body we've always known, and challenge the way we see ourselves. This workshop will support those recovering from injury, and share tools for cultivating a healthy body image.

October 4, 2023 Grief, A One Man Sh'tshow

After a drunk driver killed both of his children in a horrific crash, playwright and filmmaker Cole Campbell channeled his shock, anguish, and rage into a tragic-comic exploration of our culture's inability to talk about grief. Following the performance, Colin joins in conversation with Joyal Mulhron, Director of Evolvere, a leading bereavement advocacy organization.

January 4, 2024 The Comfort of Our Pets

We know that the company of animals makes us feel good. Extensive research proves it. Pets have the ability to relieve stress and anxiety, lower blood pressure, and boost our mood. We'll share conversation, visits from pets who want to be on camera, and resources for pet therapy.

April 4, 2024 Somatic Movement Therapy for Crash Survivors

This workshop will guide people to access the parasympathetic nervous system - the system that helps us to 'rest and digest' - through simple movements and awareness building. The benefits include slowing heart and breathing rates, lowering blood pressure, and promoting digestion and other functions.

August 23, 2023 Haiku Writing

The ancient tradition of Haiku poetry or "play verse" focuses on themes including the temporality of life, the temporality of nature, and the seasons. These are very short poems that nonetheless pack a punch. Together we will discuss and explore the power of this kind of poetry writing and create our own poems. ALL WRITING ABILITIES WELCOME!

November 21, 2023 World Day of Remembrance for Road Traffic Victims

Join FSS community members from across the country for a virtual candle lighting and memorial slideshow to remember loved ones and share impressions from our World Day of Remembrance memorials.

February 1, 2024 Show & Tell: Remembering Loved Ones

Photos, objects and memories can help tell a story about loved ones we've lost. These treasures can hold significant meaning that helps us to share stories and feel close to our loved ones and to the community that supports us. Join peers from across the country to share special objects and remembrances.

May 2, 2024 Surviving the Holidays

After the sudden loss of a loved one, holidays can be the time when we miss our loved ones most. This is also the time when we most need support from others who understand. Community members share strategies for remembering loved ones during holidays, creating new traditions, and finding solace at a difficult time.

September 7, 2023 Forest Bathing: A Guided Introduction

The solace and comfort that the natural world offers can have tremendous therapeutic benefits. Forest Bathing, also known as Shinrin Yoku, was developed in Japan in the 1980s as an effective tool to overcome the effects of a hectic life and stressful work environment, by providing guided, immersive experiences in a natural setting of any kind.

December 7, 2023 Virtual Sound Bath Meditation

A sound bath or sound healing is an ancient tradition using instruments with deep, resonating vibrations like Tibetan singing bowls, bells, chimes, and gongs to release tension and ease stress, fatigue, and depression. A great way for beginners to learn about meditation - and open to everyone.

March 2, 2024 Connecting & Reflecting Through

The craze to explore much-needed other hard hands-on of calm ca



RESOURCE GUIDE

Introduction	3
Five Important Considerations After Your Crash	5
Emotional Support	9
Hospitals, Visiting Nurse Service, and Physical Therapy	15
Driver Accountability and an Overview of the Legal System	15
NYPD Crash Investigation	17
Civil Lawyers	20
Insurance/Compensation and Civil Court	24
District Attorneys and the Criminal Process	39
Department of Motor Vehicles Hearings	48
Public Vehicle License/Employment Hearings	51
Advocacy: Fighting Back and Making Change	52
Additional Resources	55
References	57

- Monthly Support Community
- Peer Mentoring
- Online Support
- Resource Guide in 3 languages
- Logistical Assistance